

# *Micro Hi-Fi Component System*

---

Operating Instructions



*CMT-SE1*

## WARNING

**To prevent fire or shock hazard, do not expose the unit to rain or moisture.**

To prevent fire, do not cover the ventilation of the apparatus with news papers, table-cloths, curtains, etc. And don't place lighted candles on the apparatus.

To prevent fire or shock hazard, do not place objects filled with liquids, such as vases, on the apparatus.

Do not install the appliance in a confined space, such as a bookcase or built-in cabinet.

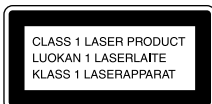

This appliance is classified as a CLASS 1 LASER product. This label is located on the rear exterior.



Don't throw away the battery with general house waste, dispose of it correctly as chemical waste.

## How to use this manual

This manual mainly explains operations using the remote, but the same operations can also be performed using the buttons on the system having the same or similar names.

# Table of Contents

How to use this manual.....	2
<hr/>	
<b>Getting Started</b>	
Hooking up the system.....	4
Setting the clock.....	5
<hr/>	
<b>CD – Play</b>	
Loading a disc .....	6
Playing a disc .....	6
— Normal Play/Shuffle Play	
Playing repeatedly .....	7
— Repeat Play	
Creating your own program .....	7
— Program Play	
<hr/>	
<b>Tuner</b>	
Presetting radio stations .....	8
Listening to the radio .....	9
— Preset Tuning	
— Manual Tuning	
Using the Radio Data System (RDS).....	10
<hr/>	
<b>Sound Adjustment</b>	
Adjusting the sound .....	11
<hr/>	
<b>Timer</b>	
Falling asleep to music.....	11
— Sleep Timer	
Waking up to music .....	12
— Daily Timer	
<hr/>	
<b>Display</b>	
Turning off the display.....	13
— Power Saving Mode	
Viewing information about the disc in the display .....	13

---

## Optional Components

Hooking up optional components.....	14
Listening to audio from a connected component .....	15
Recording on a connected component .....	15

---

## Troubleshooting

Problems and remedies.....	16
Messages.....	18

---

## Additional Information

Precautions.....	19
Specifications.....	20
List of button locations and reference pages .....	22

## Getting Started

# Hooking up the system

Perform the following procedures **1** to **3** to hook up your system using the supplied cords and accessories.

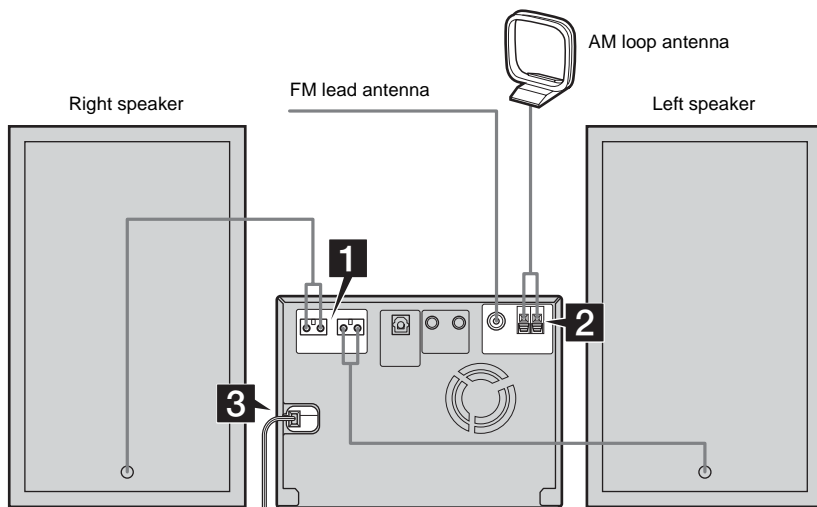

### **1** Connect the speakers.

Connect the right and left speaker cords to the SPEAKER terminals as shown below.

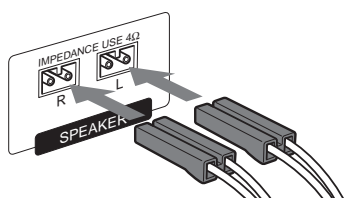

### **2** Connect the FM and AM antennas.

Set up the AM loop antenna, then connect it.

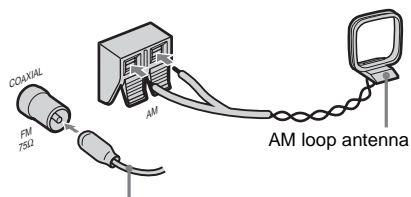
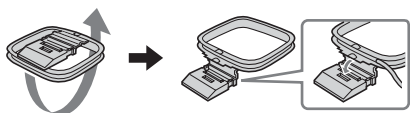

Extend the FM lead antenna horizontally

#### Note

To prevent noise pickup, keep the antennas away from the system and other components.

### **3** Connect the mains lead to mains.

If the plug does not fit the wall socket, detach the supplied plug adaptor (only for models equipped with an adaptor).

To turn on the system, press I/O.

## Attaching the speaker pads

Attach the supplied speaker pads to the bottom of the speakers to stabilize the speakers and prevent them from slipping.

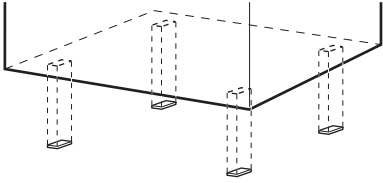

## Inserting two R6 (size AA) batteries into the remote

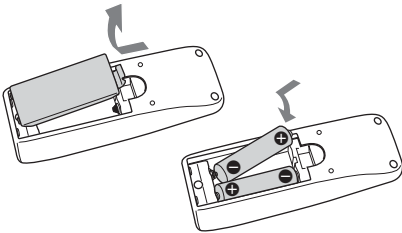

### Note

If you do not use the remote for a long period of time, remove the batteries to avoid possible damage from battery leakage and corrosion.

### Tip

When the remote no longer operates the system, replace both batteries with new ones.

## Opening the front cover

Pull down the upper right corner of the front cover on the unit.

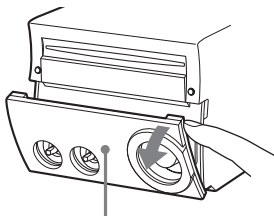

Front cover

## Setting the clock

- 1 Press I/⏻ to turn on the system.
- 2 Press CLOCK/TIMER SET.
- 3 Press I◀◀ or ▶▶I repeatedly to set the hour.
- 4 Press ENTER.
- 5 Press I◀◀ or ▶▶I repeatedly to set the minute.
- 6 Press ENTER.

The clock starts working.

To adjust the clock

- 1 Press CLOCK/TIMER SET.
- 2 Press I◀◀ or ▶▶I until "CLOCK SET?" appears, then press ENTER.
- 3 Do the same procedures as step 3 to 6 above.

### Note

The clock is not displayed in Power Saving Mode.

### Tip

When you adjust the clock while the system is off, do the same procedures as step 2 to 6 above.

## CD – Play

### Loading a disc

- 1 Press **CD** (or **FUNCTION** on the unit repeatedly) to switch the function to **CD**.
- 2 Insert a disc in the disc slot with the label side up.

When you play a disc, insert it with the label side up.

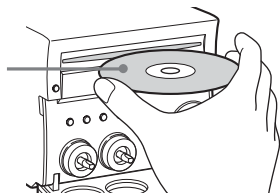

#### Notes

- When you turn on the system, the disc is not pulled into the disc slot until “CD No Disc” appears in the display. Do not attempt to push in the disc until “CD No Disc” appears.
- Do not use a disc with tape, seals or paste on it as this may cause malfunction.

## Playing a disc

### — Normal Play/Shuffle Play

This system lets you play CD in different play modes.



- 1 Press **CD** (or **FUNCTION** on the unit repeatedly) to switch the function to **CD**.
- 2 Press **PLAY MODE** in stop mode repeatedly until the mode you want appears.

Select	To play
No display (Normal Play)	The tracks on the disc in original order.
SHUFFLE (Shuffle Play)	All tracks on the disc in random order.
PROGRAM (Program Play)	The tracks on the disc in the order you want them to be played (see “Creating your own program” on page 7).

- 3 Press **▶**.

### Other operations

To	Do this
Stop play	Press <b>■</b> .
Pause	Press <b>  </b> . Press again to resume play.
Select a track	Press <b>◀◀</b> or <b>▶▶</b> repeatedly.
Find a point in a track	Keep pressing <b>◀◀</b> or <b>▶▶</b> during playback and release it at the desired point.
Remove a disc	Press <b>▲</b> EJECT on the unit.

#### Note

You cannot change the play mode during playback.

#### Tip

When disc access takes a long time, set “CD PowerOn” by CD power manage function (page 9).

## Playing repeatedly

### — Repeat Play

You can play all the tracks or a single track on a disc repeatedly.

Press **REPEAT** repeatedly during playback until “REPEAT” or “REPEAT 1” appears.

REPEAT: For all the tracks on the disc up to five times.

REPEAT 1: For a single track only.

To cancel Repeat Play

Press REPEAT repeatedly until both “REPEAT” and “REPEAT 1” disappear.

#### Note

When you select “REPEAT 1”, that track is repeated endlessly until “REPEAT 1” is canceled.

## Creating your own program

### — Program Play

You can make a program of up to 25 steps.

- 1 Press **CD** (or **FUNCTION** on the unit repeatedly) to switch the function to **CD**.
- 2 Press **PLAY MODE** in stop mode repeatedly until “PROGRAM” appears.
- 3 Press **◀◀** or **▶▶** repeatedly until the desired track number appears.

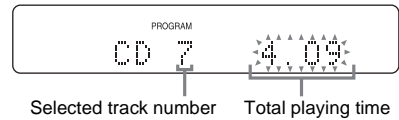

- 4 Press **ENTER**.

The track is programmed.

The step number appears, followed by the last programmed track number.

- 5 To program additional tracks, repeat steps 3 and 4.

- 6 Press **▶**.

Program Play starts.

### Other operations

To	Do this
Cancel Program Play	Press <b>PLAY MODE</b> in stop mode repeatedly until “PROGRAM” disappears.
Clear a track from the end	Press <b>CLEAR</b> in stop mode.
Add a track to the end of the program	Perform steps 3 and 4 in stop mode.

#### Tips

- The program you made remains after Program Play finishes. To play the same program again, press **▶**. However, the program is cleared when you eject the disc.
- “- - -” appears when the total program time exceeds 100 minutes, or when you select a CD track numbered 21 or over.

## Presetting radio stations

You can preset up to 20 FM stations and 10 AM stations. You can then tune in any of those stations simply by selecting the corresponding preset number.

### Automatic tuning preset

You can automatically tune in all of the stations that can be received in your area and then store the radio frequency of the desired stations.

- 1 Press **TUNER/BAND** repeatedly (or move lever on the unit to FM or AM) to select “FM” or “AM”.
- 2 Press **TUNING MODE** repeatedly until “AUTO” appears in the display.
- 3 Press **TUNING +/-**.

The frequency changes as the system scans for a station. Scanning stops automatically when a station is tuned in. At that time, “TUNED” and “STEREO” (for stereo program only) appear.

**If “TUNED” does not appear and the scanning does not stop**

Set the frequency of the desired radio station as described in steps 2 and 3 of “Manual tuning preset” (page 8).

- 4 Press **TUNER MEMORY**.

The preset number flashes. Perform steps 5 and 6 while the preset number flashes.

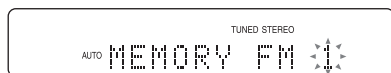

Preset number

- 5 Press **PRESET +/-** repeatedly to select the desired preset number.
- 6 Press **ENTER**.
- 7 Repeat steps 1 through 6 to preset other stations.

Tip

Press **TUNING MODE** to stop scanning.

### Manual tuning preset

You can manually tune in and store the radio frequency of the desired stations.

- 1 Press **TUNER/BAND** repeatedly (or move lever on the unit to FM or AM) to select “FM” or “AM”.
- 2 Press **TUNING MODE** repeatedly until both “AUTO” and “PRESET” disappear from the display.
- 3 Press **TUNING +/-** repeatedly to tune in the desired station.
- 4 Press **TUNER MEMORY**.
- 5 Press **PRESET +/-** repeatedly to select the desired preset number.
- 6 Press **ENTER**.
- 7 Repeat steps 1 through 6 to preset other stations.

### Other operations

To	Do this
Tune in a station with a weak signal	Follow the procedure described in “Manual tuning preset” (page 8).
Set another station to the existing preset number	After step 4, press <b>PRESET +/-</b> repeatedly to select the preset number you want to store the station.

Tips

- The preset stations are retained for about half a day even if you disconnect the mains lead or if a power failure occurs.
- To improve the reception, adjust the supplied antennas or connect an external antenna.



## To improve tuner reception

When tuner reception is poor, set CD player power off by CD power manage function. CD power is factory set to on.

- 1 Press CD (or FUNCTION on the unit repeatedly) to switch the function to CD.
- 2 Press I/⏻ to turn off the system.
- 3 Press I/⏻ while holding ■. "CD PowerOff" appears.

## To set CD power on

Repeat the procedure above and "CD PowerOn" appears.

### Notes

- When "CD PowerOff" is selected, disc access time is increased.
- You cannot change the setting in Power Saving Mode.

## Listening to the radio

You can listen to a radio station either by selecting a preset station, or by manually tuning in the station.

### Listening to a preset station

#### — *Preset Tuning*

Preset radio stations in the tuner's memory first (see "Presetting radio stations" on page 8).

- 1 Press TUNER/BAND repeatedly (or move lever on the unit to FM or AM) to select "FM" or "AM".
- 2 Press TUNING MODE repeatedly until "PRESET" appears in the display.
- 3 Press PRESET +/- repeatedly to select the desired preset station.

### Listening to non-preset radio station

#### — *Manual Tuning*

- 1 Press TUNER/BAND repeatedly (or move lever on the unit to FM or AM) to select "FM" or "AM".
- 2 Press TUNING MODE repeatedly until both "AUTO" and "PRESET" disappear from the display.
- 3 Press TUNING +/- repeatedly to tune in the desired station.

### Tips

- To improve broadcast reception, adjust the supplied antennas, or connect a commercially available external antenna.
- When an FM stereo program has static noise, press FM MODE repeatedly until "MONO" appears. There will be no stereo effect, but the reception will improve.
- Press TUNING MODE repeatedly until "AUTO" appears in step 2 above, then press TUNING +/- . The frequency indication changes and scanning stops automatically when the system tunes in a station (Automatic Tuning).

## Using the Radio Data System (RDS)

### What is the Radio Data System?

Radio Data System (RDS) is a broadcasting service that allows radio stations to send additional information along with the regular program signal. RDS is available only on FM stations.\*

#### Note

RDS may not work properly if the station you are tuned in is not transmitting the RDS signal properly or if the signal is weak.

\* Not all FM stations provide RDS service, nor do they provide the same types of services. If you are not familiar with the RDS system, check with your local radio stations for details on RDS services in your area.

### Receiving RDS broadcasts

#### **Simply select a station from the FM band.**

When you tune in a station that provides RDS services, the station name appears in the display.

#### To check the RDS information

Each time you press DISPLAY, the display changes cyclically as follows:

Station name\* → Frequency → Clock display  
→ Bass level → Treble level

\* If the RDS broadcast is not properly received, the station name may not appear in the display.

## Sound Adjustment

### Adjusting the sound

You can adjust the bass and treble to enjoy more powerful sound.

#### Generating a more dynamic sound (Dynamic Bass Feed Back)

DBFB is factory set to on.

**To cancel the DBFB, press DBFB.**

#### Adjusting the bass and treble

You can adjust the bass and treble.

**Press BASS +/- or TREBLE +/- repeatedly to adjust the level you want to set.**

To adjust the bass and treble on the unit

**1** Press BASS/TREBLE on the unit repeatedly to select "BASS" or "TREBLE".

Each time you press the button, the display changes as follows:

BASS ↔ TREBLE

**2** Press +/- on the unit repeatedly to adjust the level while "BASS" or "TREBLE" appears.

To exit the bass and treble settings

Press any button other than BASS +/-, TREBLE +/-, BASS/TREBLE on the unit or +/- on the unit.

Also, if you do not perform any operations for a few seconds, the display automatically returns to the original display.

## Timer

### Falling asleep to music

#### — Sleep Timer

You can set the system to turn off after a certain time, so that you can fall asleep to music.

**Press SLEEP.**

Each time you press the button, the minute display (the turn-off time) changes cyclically as follows:

AUTO\* → 90min → 80min → ... → 10min → OFF

\* The system automatically turns off in 240 minutes or after the current CD finishes playing.

#### Other operations

To	Do this
Check the remaining time**	Press SLEEP once.
Change the time to turn off	Press SLEEP repeatedly to select the time you want.
Cancel the Sleep Timer Function	Press SLEEP repeatedly until "OFF" appears.

\*\* You cannot check the remaining time if you select "AUTO".

#### Tip

You can use the Sleep Timer, even if you have not set the clock.

# Waking up to music

## — Daily Timer

You can wake up to music at a preset time. Make sure you have set the clock (see “Setting the clock” on page 5).

### 1 Prepare the sound source you want to play.

- CD: Insert a disc. To start from a specific track, make a program (see “Creating your own program” on page 7).
- TUNER: Tune in the preset radio station (see “Listening to the radio” on page 9).

### 2 Press VOL +/- (or turn VOLUME control on the unit) to adjust the volume.

### 3 Press CLOCK/TIMER SET.

### 4 Press ◀◀ or ▶▶ repeatedly until “DAILY SET ?” appears, then press ENTER.

### 5 Set the time to start playing.

Press ◀◀ or ▶▶ repeatedly to set the hour, then press ENTER.

The minute indication flashes.

Press ◀◀ or ▶▶ repeatedly to set the minute, then press ENTER.

### 6 Set the time to stop playing following the same procedure as step 5.

### 7 Press ◀◀ or ▶▶ repeatedly until the desired sound source appears.

Each time you press the button, the display changes cyclically as follows:

TUNER ↔ CD PLAY

### 8 Press ENTER.

The start time, the stop time, the sound source and the volume appear in turn, then the original display returns.

### 9 Press I/⏻ to turn off the system.

## Other operations

To	Do this
Check the setting	<ol style="list-style-type: none"><li>1 Press CLOCK/TIMER SELECT.</li><li>2 Press ◀◀ or ▶▶ repeatedly until “DAILY ON?” appears, then press ENTER.</li></ol>
Change the setting	Start over from step 1.
Cancel the timer	<ol style="list-style-type: none"><li>1 Press CLOCK/TIMER SELECT.</li><li>2 Press ◀◀ or ▶▶ repeatedly until “DAILY OFF?” appears, then press ENTER.</li></ol>

### Notes

- If you use the Daily Timer and the Sleep Timer at the same time, the Sleep Timer has priority.
- If the system is on about 15 seconds before the preset time, the Daily Timer will not be activated.
- You cannot use the optional component connected to MD (TAPE) IN jack as the sound source for Daily Timer.

### Turning off the display

#### — Power Saving Mode

The clock display can be turned off to minimize the amount of power consumed during standby (Power Saving Mode).

**Press DISPLAY repeatedly while the system is off until the clock display disappears.**

To cancel Power Saving Mode

Press DISPLAY while the system is off. Each time you press the button, the display switches cyclically as follows:

Clock display\* ↔ No display (Power Saving Mode)

\* The clock is displayed only if you set the clock.

#### Note

You cannot perform the following operations in Power Saving Mode.

- setting the clock
- changing the CD power manage function
- switching the MD (TAPE) function

#### Tips

- I/⏻ indicator lights up even in Power Saving Mode.
- The timer continues to operate in Power Saving Mode.

## Viewing information about the disc in the display

You can check the playing time and remaining time of the current track or that of the disc.

### Checking the remaining time and titles (CD)

#### Press DISPLAY during Normal Play.

Each time you press the button, the display changes cyclically as follows:

Current track number and elapsed playing time

→ Current track number and remaining time →

Remaining time of the disc\*<sup>1</sup> → Track title of

CD-TEXT disc\*<sup>2</sup> → Clock display →

Bass level → Treble level

\*<sup>1</sup> “-.-.-” appears in Program Play mode.

\*<sup>2</sup> When the disc contains more than 20 tracks, CD-TEXT is not displayed from track 21 on.

### Checking the total playing time and titles (CD)

#### Press DISPLAY in stop mode.

Each time you press the button, the display changes cyclically as follows:

Total playing time → Disc title\* →

Clock display → Bass level → Treble level

\* For CD-TEXT discs (certain characters cannot be displayed).

#### Note

When fast forward or fast reverse is performed, elapsed playing time and remaining time of the track may not be displayed accurately.

## Optional Components

### Hooking up optional components

To enhance your system, you can connect optional components. Refer to the operating instructions provided with each component.

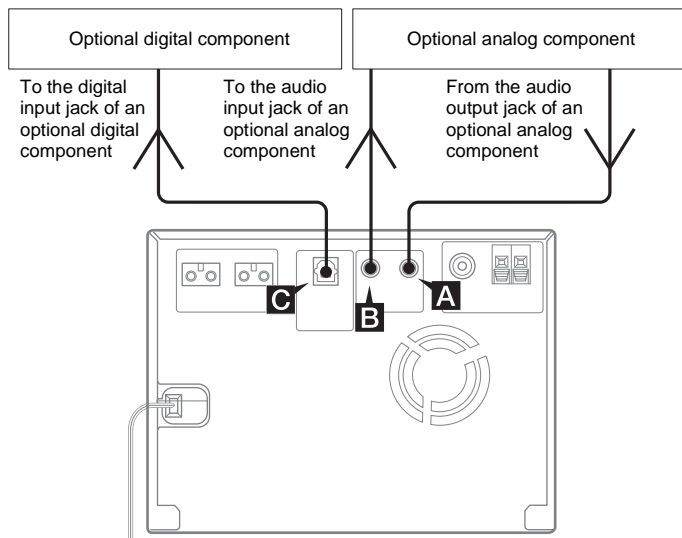

**A** MD (TAPE) IN jack (stereo mini jack)

Use audio cord (not supplied) to connect an optional analog component (MD deck or tape deck, etc.) to this jack. You can then listen to the sound from the component.

**B** MD (TAPE) OUT jack (stereo mini jack)

Use audio cord (not supplied) to connect an optional analog component (MD deck or tape deck, etc.) to this jack. You can then listen to the sound through this system.

**C** CD OPTICAL OUT DIGITAL jack

Use a digital optical cable (square, not supplied) to connect an amplifier, MD deck, or DAT deck with a digital optical input jack. Digital signal is output only when the system function is set to CD. If the jack is covered with a cap, remove it before use.

## Listening to audio from a connected component

Listening to a connected MD deck

- 1 Connect the audio cord.**  
See “Hooking up optional components” on page 14.
- 2 Press MD (TAPE) (or FUNCTION on the unit) repeatedly until “MD” appears.**  
Start playing the connected component.

Listening to a connected tape deck

- 1 Connect the audio cord.**  
See “Hooking up optional components” on page 14.
- 2 Press MD (TAPE) (or FUNCTION on the unit) repeatedly until “TAPE” appears.**  
Hold down FUNCTION on the unit and press I/⏏ on the unit. This switches the MD function to TAPE. Once you enable the TAPE function, just press MD (TAPE).

### Tip

If you cannot select “MD” by pressing MD (TAPE) (or FUNCTION on the unit) repeatedly, turn off the system and then press I/⏏ on the unit while holding down FUNCTION on the unit. The function will change from “TAPE” to “MD”, and “MD” will appear in the display. To change back to “TAPE”, repeat the same procedure. However, you cannot switch the MD/TAPE function in Power Saving Mode.

## Recording on a connected component

Making an analog recording

- 1 Connect the audio cord.**  
See “Hooking up optional components” on page 14.
- 2 Start recording.**  
Refer to the operating instructions provided with connected component.

Making a digital recording

- 1 Connect the digital optical cable.**
- 2 Start recording.**  
Refer to the operating instructions provided with connected component.

### Note

You can digitally record from the discs only. However, you cannot record from copy prohibited discs.

### Problems and remedies

Should you encounter a problem with your system, do the following:

- 1 Make sure the mains lead and speaker cords are correctly and firmly connected.
- 2 Find your problem in the troubleshooting checklist below and take the indicated corrective action.

If the problem persists after doing all of the above, consult your nearest Sony dealer.

#### When the I/⏻ indicator flashes

Immediately unplug the mains lead and check the following items.

- Are the system control cables connected correctly?
- If your system has a voltage selector, is the voltage selector set to the correct voltage? Check the voltage for your region, then make sure the voltage selector is set correctly.
- Are the + and – speaker cords short-circuited?
- Are you using the supplied speakers?
- Is anything blocking the ventilation holes on the rear of the system?

Check all the above items and fix any problems found. After I/⏻ indicator stops flashing, reconnect the mains lead and turn on the system. If the indicator still flashes, or if the cause of the problem cannot be found even after checking all the above items, consult your nearest Sony dealer.

## General

---

### “--:--” appears in the display.

- A power interruption has occurred. Set the clock (page 5) and timer setting (page 12) again.

---

### The clock setting/radio presetting/timer is canceled.

- Redo the following:
  - “Setting the clock” (page 5)
  - “Presetting radio stations” (page 8)
  - “Check the setting” (page 12)

---

### There is no sound.

- Press VOL +/- or turn VOLUME control on the unit clockwise.
- Make sure the headphones are not connected.
- Check the speaker connections (page 4).

---

### Sound comes from one channel, or unbalanced left and right volume.

- Place the speakers as symmetrically as possible.
- Connect the supplied speakers.

---

### Sound lacks bass.

- Check that the speaker’s + and – jacks are connected correctly.

---

### There is severe hum or noise.

- Move the system away from the source of noise.
- Connect the system to a different mains.
- Install a noise filter (commercially available) to the mains line.

---

### The timer cannot be set.

- Set the clock again (page 5).

---

### The timer does not function.

- Press CLOCK/TIMER SELECT to set the timer and light up “DAILY” in the display (page 12).
- Check the timer setting and set the correct time (page 12).
- Cancel the Sleep Timer Function (page 11).
- Make sure the clock is correctly set.

---

### The color on the TV screen is irregular.

- Move the speakers farther away from the TV set.

---

### The remote does not function.

- Remove the obstacle.
  - Move the remote closer to the system.
  - Point the remote at the system’s sensor.
  - Replace the batteries (R6/size AA).
  - Locate the system away from the fluorescent light.
-



**“LOCKED” appears.**

- Contact your Sony dealer or local authorized Sony service facility.

**The disc does not eject.**

- Consult your nearest Sony dealer.

**Play does not start.**

- Check whether a disc is loaded (The DISC indicator lights up when a disc is loaded).
- Wipe the disc clean (page 19).
- Replace the disc.
- Load the disc that this system can play.
- Load the disc correctly.
- Load the disc in the player with the label side up.
- Remove the disc and wipe away the moisture on the disc, then leave the system turned on for a few hours until the moisture evaporates.
- Press ► to start play.

**Disc access takes a long time.**

- Set “CD PowerOn” by CD power manage function (page 9).

**The sound skips.**

- Wipe the disc clean (page 19).
- Replace the disc.
- Try moving the system to a place without vibration (e.g., on top of a stable stand).
- Try moving the speakers away from the system, or placing them on separate stands. When you listen to a track with bass sounds at high volume, the speaker vibration may cause the sound to skip.

**Play does not start from the first track.**

- Press PLAY MODE repeatedly until both “PROGRAM” and “SHUFFLE” disappear to return to Normal Play.

**Severe hum or noise/stations cannot be received.**

- Set the proper band and frequency (page 8).
- Connect the antenna properly (page 4).
- Find a place and an orientation that provide good reception, then set up the antenna again. If you cannot obtain good reception, we recommend you connect a commercially available external antenna.
- The supplied FM lead antenna receives signals along its entire length, so make sure you extend it fully.
- Keep the antennas away from the system and other components.
- Consult your nearest Sony dealer if the supplied AM antenna has come off the plastic stand.
- Try turning off surrounding electrical equipment.
- Set “CD PowerOff” by CD power manage function (page 9).

**A stereo FM program cannot be received in stereo.**

- Press FM MODE until “MONO” disappears from the display.

**Optional components****There is no sound.**

- Refer to General item “There is no sound.” (page 16) and check the condition of the system.
- Connect the component properly (page 14) while checking:
  - if the cords are connected properly.
  - if the cord plugs are firmly inserted all the way.
- Turn on the connected component.
- Refer to the operating instructions supplied with the connected component and start playing.
- Press MD (TAPE) (or FUNCTION on the unit) repeatedly to select “MD” or “TAPE” (page 15).

**The sound is distorted.**

- Set the volume of the connected component lower.

If the system still does not operate properly after performing the above measures, reset the system as follows:

- 1 Disconnect the mains lead.
- 2 Reconnect the mains lead.
- 3 Press I/⏻ to turn on the system.
- 4 Move lever on the unit to ■ and press FUNCTION and I/⏻ on the unit.

The system is reset to the factory settings. You should set the settings you made, such as the preset stations, clock, and timer.

## Messages

One of the following messages may appear or flash in the display during operation.

### CD

---

#### **No Disc**

There is no disc in the player.

---

#### **No Step**

All of the programmed tracks have been erased.

---

#### **Over**

You have reached the end of the disc while pressing ►► during playback or pause.

---

#### **Push STOP!**

You pressed PLAY MODE during playback.

---

#### **Step Full!**

You tried to program 25 or more tracks (steps).

---

### TUNER

---

#### **Complete!**

The preset operation ended normally.

---

### TIMER

---

#### **OFF TIME NG**

The Daily Timer start and end times are set to the same time.

---

#### **SET CLOCK!**

You tried to set the timer, before you set the clock.

---

#### **SET TIMER!**

You pressed CLOCK/TIMER SELECT, before you set the timer.

---

## Additional Information

### Precautions

#### On operating voltage

Before operating the system, check that the operating voltage of your system is identical with the voltage of your local power supply.

#### On safety

- The unit is not disconnected from the AC power source (mains) as long as it is connected to the wall outlet, even if the unit itself has been turned off.
- Unplug the system from the wall outlet (mains) if it is not to be used for an extended period of time. To disconnect the power cord (mains lead), pull it out by the plug. Never pull the cord itself.
- Should any solid object or liquid fall into the system, unplug the system and have it checked by qualified personnel before operating it any further.
- AC power cord (mains lead) must be changed only at the qualified service shop.

#### On placement

- Do not place the system in an inclined position.
- Do not place the system in locations where it is;
  - Extremely hot or cold
  - Dusty or dirty
  - Very humid
  - Subject to vibrations
  - Subject to direct sunlight.
- Use caution when placing the unit or speakers on surfaces that have been specially treated (with wax, oil, polish, etc.) as staining or discoloration of the surface may result.

#### On heat buildup

- Although the system heats up during operation, this is not a malfunction.
- Place the system in a location with adequate ventilation to prevent heat build-up in the system.
- If you continuously use this system at a high volume, the cabinet temperature of the top, side and bottom rises considerably. To avoid burning yourself, do not touch the cabinet.
- To prevent a malfunction, do not cover the ventilation hole.

#### On operation

- If the system is brought directly from a cold to a warm location, or is placed in a very damp room, moisture may condense on the lens inside the CD player. Should this occur, the system will not operate properly. Remove the disc and leave the system turned on for about an hour until the moisture evaporates.
- When you move the system, take out any disc.

If you have any questions or problems concerning your system, please consult your nearest Sony dealer.

#### Notes on discs

- Before playing, clean the disc with a cleaning cloth. Wipe the disc from the center out.
- Do not use solvents such as benzene, thinner, commercially available cleaners or anti-static spray intended for vinyl LPs.
- Do not expose the disc to direct sunlight or heat sources such as hot air ducts, nor leave it in a car parked in direct sunlight.
- Do not use discs encircled with a protection ring. This may cause a malfunction to the system.
- When using discs that have glue or similar tacky substance on the label side of the disc or that used a special ink when the label was printed, there is a chance that the disc or label may become attached to parts inside this unit. When this occurs, it may not be possible to remove the disc, and may also cause this unit to malfunction. Be sure to check that the label side of the disc is not sticky before using.  
The following types of disc should not be used:
  - Rental or used discs with attached seals where the glue extends beyond the seal. The perimeter of the seal on the disc is tacky.
  - Discs that have labels printed using a special ink that feels tacky when touched.
- Discs with non-standard shapes (e.g., heart, square, star) cannot be played on this unit. Attempting to do so may damage the unit. Do not use such discs.

#### Notes on CD-R and CD-RW

- This system can play CD-R/CD-RW discs edited by the user. However, note that playback of some discs may not be possible depending on the recording device used for recording or the disc condition.
- CD-R and CD-RW discs that have not been finalized (processing to allow play by a normal CD player) cannot be played.
- CD-R and CD-RW discs recorded in multi-session mode are not supported.

Music discs encoded with copyright protection technologies

This product is designed to playback discs that conform to the Compact Disc (CD) standard. Recently, various music discs encoded with copyright protection technologies are marketed by some record companies. Please be aware that among those discs, there are some that do not conform to the CD standard and may not be playable by this product.

### Cleaning the cabinet

Clean the cabinet, panel and controls with a soft cloth slightly moistened with mild detergent solution. Do not use any type of abrasive pad, scouring powder or solvent such as thinner, benzene or alcohol.

## Specifications

### Main Unit (HCD-SE1)

#### Amplifier section

DIN power output (rated): 55 + 55 W  
(4 ohms at 1 kHz, DIN)  
Continuous RMS power output (reference):  
80 + 80 W  
(4 ohms at 1 kHz, 10% THD)

#### Inputs

MD (TAPE) IN (stereo mini jack):  
Sensitivity 450/250 mV,  
impedance 47 kilohms

#### Outputs

##### CD OPTICAL OUT DIGITAL:

Optical Wavelength:  
660 nm

PHONES: Accepts headphones with an impedance of 8 ohms or more

MD (TAPE) OUT (stereo mini jack):

Impedance 1 kilohm

SPEAKER: Accepts impedance of 4 ohms

#### CD player section

Laser Semiconductor laser  
(CD:  $\lambda=780$  nm)  
Emission duration:  
continuous

Frequency response 2 Hz – 20 kHz

Wavelength 780 – 790 nm

#### Tuner section

FM stereo, FM/AM superheterodyne tuner

##### FM tuner section

Tuning range 87.5 – 108.0 MHz  
(50 kHz step)

Antenna FM wire antenna

Antenna terminals 75 ohms unbalanced

Intermediate frequency 10.7 MHz

##### AM tuner section

Tuning range 531 – 1,602 kHz  
(9 kHz step)

Antenna AM loop antenna, external antenna terminal

Intermediate frequency 450 kHz

## Speaker (SS-SE1)

Speaker system	2-way, bass-reflex type
Speaker units	
Woofer:	13 cm dia., cone type
Tweeter:	2.5 cm dia., soft-dome-type
Nominal impedance	4 ohms

## General

Power requirements	230 V AC, 50/60 Hz
Power consumption	45 W
	0.3 W (in Power Saving mode)
Dimensions (w/h/d) incl. projecting parts and controls	
Amplifier/Tuner/CD section:	Approx. 155 × 119 × 289 mm
Speakers:	Approx. 160 × 280 × 270 mm
Mass	
Amplifier/Tuner/CD section:	Approx. 3.0 kg
Speakers:	Approx. 4.0 kg net per speaker
Supplied accessories	Remote (1) R6 (size AA) batteries (2) AM loop antenna (1) FM lead antenna (1) Speaker pads (8)

Design and specifications are subject to change without notice.

# List of button locations and reference pages

## How to use this page

Use this page to find the location of buttons and other parts of the system that are mentioned in the text.

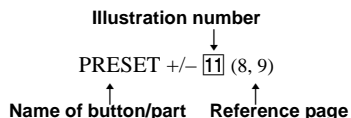

## Main unit

### ALPHABETICAL ORDER

#### A - O

AM **11** (8, 9)  
 BASS/TREBLE **12** (11)  
 DBFB **3** (11)  
 Disc slot **4**  
 Display window **5**  
 FM **11** (8, 9)  
 Front cover **7**  
 FUNCTION **14** (6, 7, 9, 15, 18)  
 Lever **11** **13**

#### P - Z

PHONES jack **9**  
 PRESET +/- **11** (8, 9)  
 Remote sensor **2**  
 VOLUME control **8** (12)

### BUTTON DESCRIPTIONS

I/⏻ (power) **1** (4, 9, 12, 15, 18)  
 ⏮/▶▶ (go back/go forward) **13** (5, 6, 12)  
 ▶▶ (play pause) **13** (6)  
 ■ (stop) **13** (6, 9, 18)  
 ▲ EJECT (eject) **6** (6)  
 +/- **10** (11)

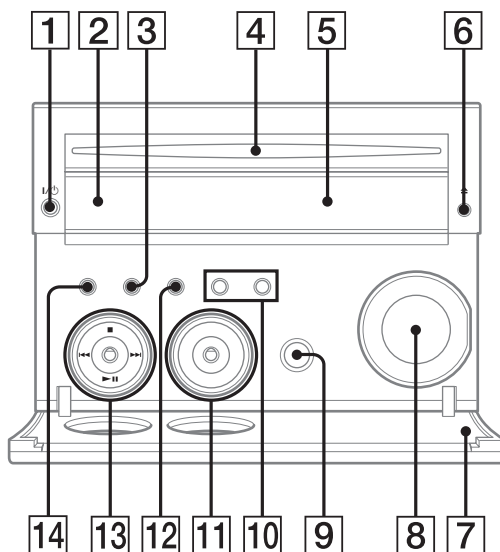

# Remote control

## ALPHABETICAL ORDER

### A - Q

- BASS +/- **20** (11)
- CD **7** (6, 7, 9)
- CLEAR **6** (7)
- CLOCK/TIMER SELECT **2** (12, 18)
- CLOCK/TIMER SET **3** (5, 12)
- DBFB **19** (11)
- DISPLAY **24** (10, 13)
- ENTER **5** (5, 7, 8, 12)
- FM MODE **9** (9)
- MD (TAPE) **23** (15)
- PLAY MODE **18** (6, 7, 18)
- PRESET +/- **17** (8, 9)

### R - Z

- REPEAT **16** (7)
- SLEEP **1** (11)
- TREBLE +/- **13** (11)
- TUNER/BAND **8** (8, 9)
- TUNER MEMORY **10** (8)
- TUNING MODE **22** (8, 9)
- TUNING +/- **14** (8, 9)
- VOL +/- **15** (12)

## BUTTON DESCRIPTIONS

- I/⏻ (power) **4** (4, 9, 12, 18)
- ▶ (play) **21** (6)
- (stop) **12** (6, 9)
- ◀◀/▶▶ (go back/go forward) **17** (5, 6, 12)
- ◀/▶ (rewind/fast forward) **14** (6, 18)
- ⏸ (pause) **11** (6)

